

# PERIMETER

SURVEYING & MAPPING  
Certificate of Authorization No. LB7264  
Prepared by: Jeff S. Holdapp, P.S.M.  
947 Clint Moore Road  
Boca Raton, Florida 33487  
Tel: (561) 241-9988  
Fax: (561) 241-5182

# ATLANTIC COMMONS - PLAT TWO

A REPLAT OF ALL OF TRACTS C AND L, "ATLANTIC COMMONS - PLAT ONE" (P.B. 115, PGS. 135-137, P.B.C.R.)  
TOGETHER WITH A PORTION OF THE SW 1/4 SECTION 16, TOWNSHIP 46 SOUTH, RANGE 42 EAST,  
PALM BEACH COUNTY, FLORIDA.

# 87

SHEET 4 OF 4

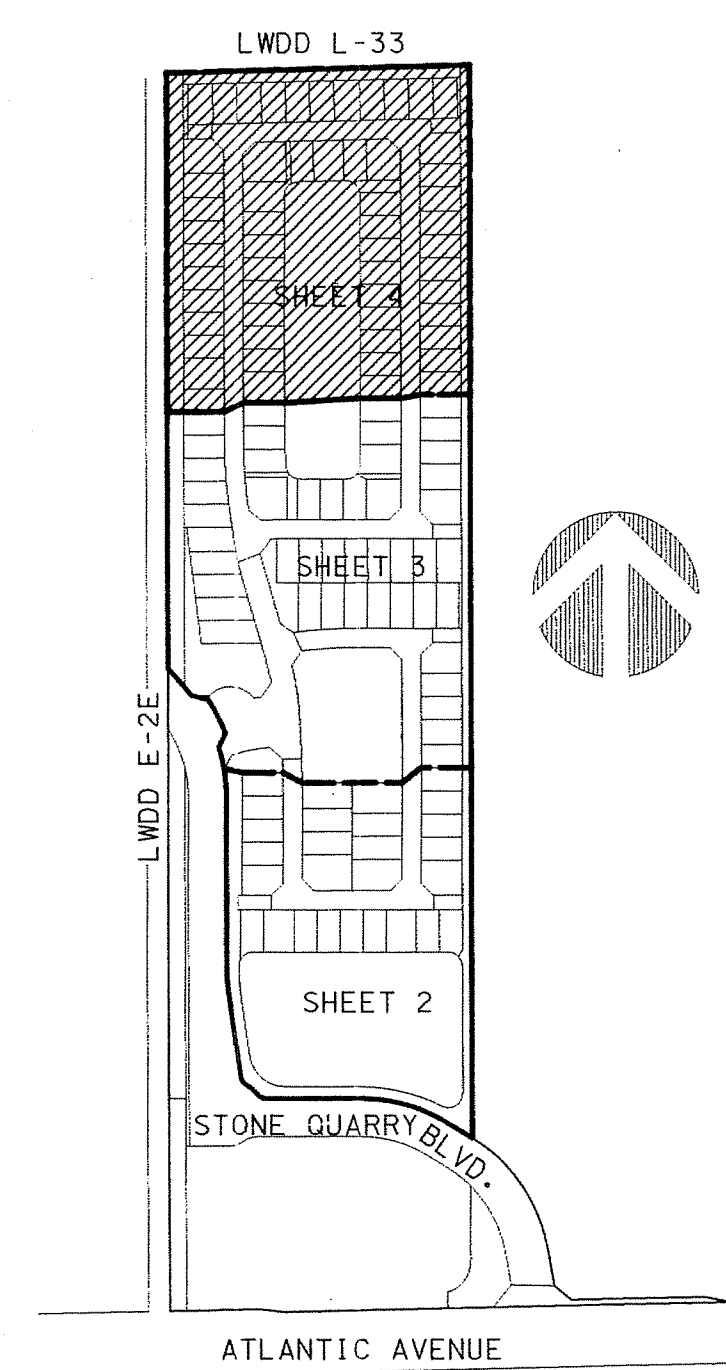
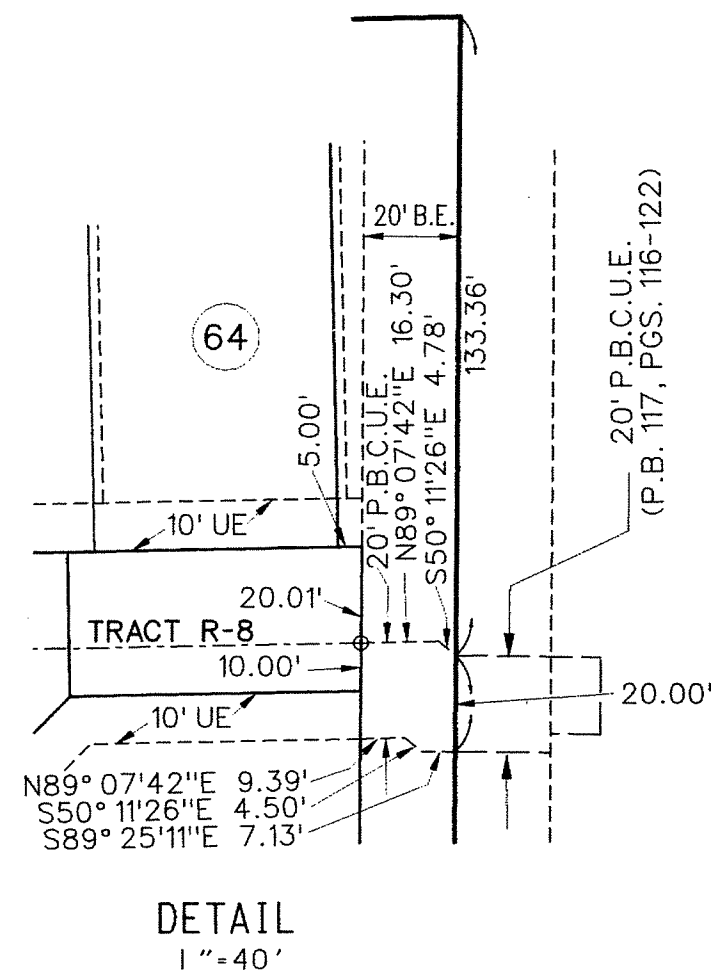
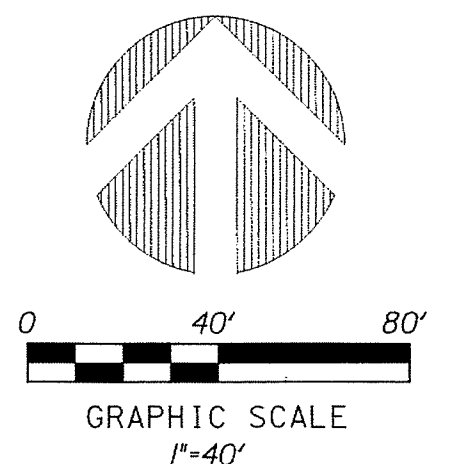
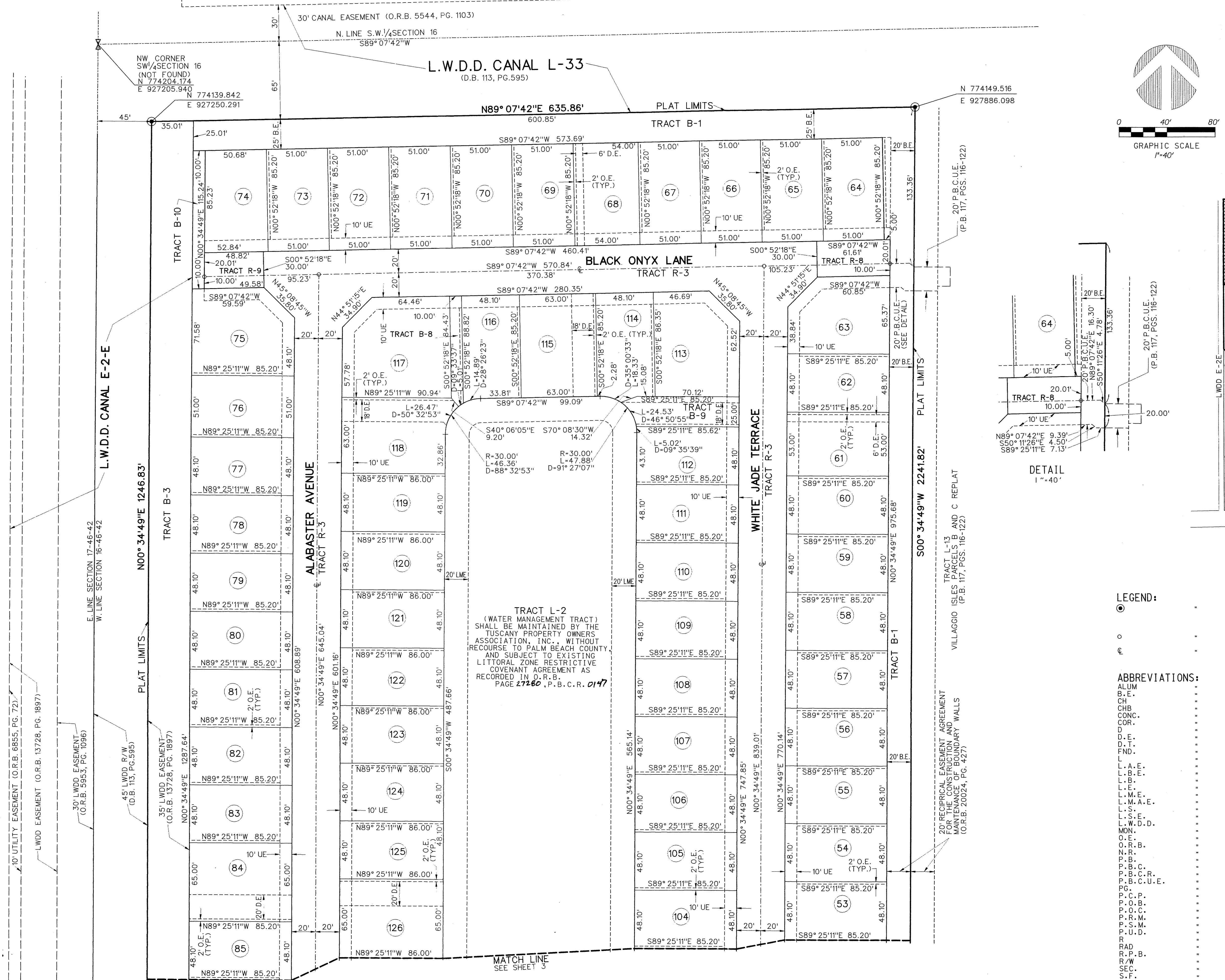

TRACT L-2  
(WATER MANAGEMENT TRACT)  
SHALL BE MAINTAINED BY THE  
TUSCANY PROPERTY OWNERS  
ASSOCIATION, INC., WITHOUT  
RECOURSE TO PALM BEACH COUNTY,  
AND SUBJECT TO EXISTING  
LITTORAL ZONE RESTRICTIVE  
COVENANT AGREEMENT AS  
RECORDED IN O.R.B.  
PAGE 27260, P.B.C.R. 0147

- LEGEND:**
- SET P.R.M. (UNLESS OTHERWISE NOTED) - 4" X 4" CONC. MON. WITH ALUMINUM DISK STAMPED P.R.M. #LB7264
  - PERMANENT CONTROL POINT (NAIL & DISK #LB7264) CENTERLINE
- ABBREVIATIONS:**
- ALUM ALUMINUM
  - BE. BUFFER EASEMENT
  - CHB CHORD BEARING
  - CONC. CONCRETE
  - COR. CORNER
  - D. DELTA (CENTRAL ANGLE)
  - D.E. DRAINAGE EASEMENT
  - D.T. DRIVEWAY TRACT
  - FND. FOUND
  - ARCLNGTH ARCLNGTH
  - L.A.E. LIMITED ACCESS EASEMENT
  - L.B.E. LANDSCAPE BUFFER EASEMENT
  - L.B. LICENSED BUSINESS
  - L.E. LANDSCAPE EASEMENT
  - L.M.E. LAKE MAINTENANCE EASEMENT
  - L.M.A.E. LAKE MAINTENANCE ACCESS EASEMENT
  - L.S. LICENSED SURVEYOR
  - L.S.E. LIFT STATION EASEMENT
  - L.W.D.D. LAKE WORTH DRAINAGE DISTRICT
  - MON. MONUMENT
  - M.O. MAINTENANCE AND ROOF OVERHANG EASEMENT
  - O.R.B. OFFICIAL RECORDS BOOK
  - NON-RADIAL NON-RADIAL
  - P.B. PALM BEACH COUNTY
  - P.B.C. PALM BEACH COUNTY RECORDS
  - P.B.C.R. PALM BEACH COUNTY UTILITY EASEMENT
  - P.C. PAGE
  - P.C.P. PERMANENT CONTROL POINT
  - P.O.B. POINT OF BEGINNING
  - P.O.C. POINT OF COMMENCEMENT
  - P.R.M. PERMANENT REFERENCE MONUMENT
  - P.S.M. PROFESSIONAL SURVEYOR & MAPPER
  - P.U.D. PLANNED UNIT DEVELOPMENT
  - R. RADIUS
  - RAD. RADIAL
  - R.P.B. ROAD PLAT BOOK
  - R/W. RIGHT-OF-WAY
  - SEC. SECTION
  - S.F. SQUARE FEET
  - U.E. UTILITY EASEMENT